

1/2

## MANHOLE COVER – LOCKED HINGED LIFT ASSISTED KFVAA - CLASS F900



### SPECIFICATIONS :

Norm : **EN 124-2**

Loading : **900 kN**

Locking : ¼ turn lock H Ø22 Stainless Steel

Quality Label : Tüv 

### MATERIAL & COATING :

**Covers** : Spheroidal Cast Iron

EN-GJS-600-10. Water Based Black Paint

**Frame** : Steel Hot-Dip Galvanized

**Hardware** : Stainless Steel

### OPTIONS :

Special lock : automatic, burglar-proof SAE

Fall safety equipment

Custom Badging & Logo

### REMARKS :

Lift Assisted by gas truts (1 per lid)  
Safety blocking to prevent accidental cover closure, activated automatically at the opening of the cover.

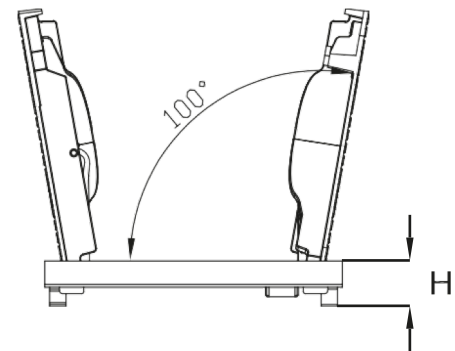
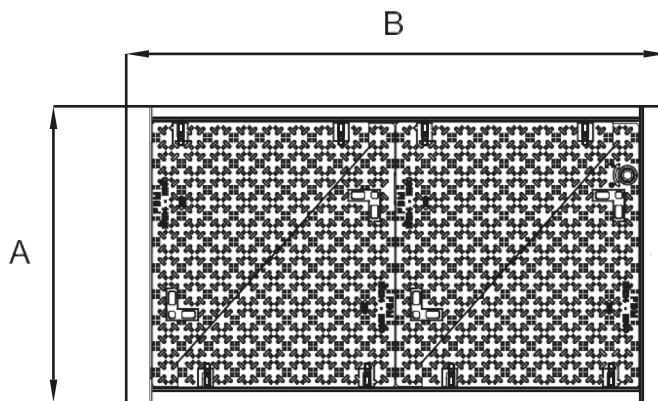

| Reference         | Description | Lay-out   | Clear opening without lids | Freeway  | A*  | B*   | H*  | Total weight |
|-------------------|-------------|---|----------------------------|----------|-----|------|-----|--------------|
|                   |             |   |                            | mm       |     |      |     | Kg           |
| 25753             | K1FVAA      |  | 750 x 750                  | 580x750  | 910 | 910  | 140 | 200          |
| 25754             | K2FVAA      |  | 750 x 1500                 | 580x1500 | 910 | 1660 | 140 | 380          |
| 25755             | K3FVAA      |  | 750 x 2250                 | 580x2250 | 910 | 2410 | 140 | 560          |
| Weight / Lid (Kg) |             |   |                            |          |     |      |     | 72           |

\*External frame measuress

All dimensions, weights and norms are given for information only. BERGTEC reserves the right to modify the specifications of products given in the present document.

2/2

## MANHOLE COVER – LOCKED HINGED LIFT ASSISTED KFVAA - CLASS F900



### BESPOKE



On request, the manhole cover can be tailor-made with a special **badging embossed** and moulded in raw material & with a topcoating colored polyester paint.

### ¼ TURN LOCK



Cam and shaft in stainless steel. Locking and unlocking by rotation of a quarter turn of the screw.

1/4 turn locking systems are equipped as **standard** with **H22 hex heads**.

On request, Soval studies and provides you with **coded and customizable systems** to reinforce the security of these closures.

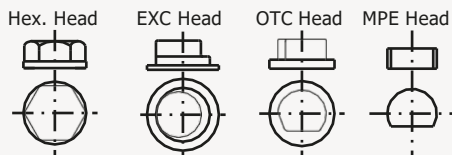

### SAFETY BLOCKING SYSTEM «PULLED & CLOSED»

Cover blocked in open position = safety



Simplified unlocking and closing: Pulled & Closed system



## Associated products

