

1/2

MANHOLE COVER - LOCKED HINGED LIFT ASSISTED ARES CLASS D400



PLACE OF INSTALLATION :

D400 Middle Traffic (T3) _ Speed limit
(50Km/h. max)

SPECIFICATIONS :

Norm : **EN 124-2**
Loading : **400 kN**
Quality Label : Tüv 

MATERIAL & COATING:

Cover & Frame : Spheroidal Cast Iron
EN-GJS-500-7. Water Based Black Paint
Hardware : Stainless Steel / Cast Iron
Gasket : EPDM monobloc

OPTIONS :

Custom Badging & Logo
Special lock : burglar-proof SAE
Standard lock : 1/4 turn



REMARKS :

Lift assisted by stainless steel mechanical springs.
Selflocking by means of ductile iron spring bar «Pushed -Slammed».
Safety blocking to prevent accidental cover closure, activated automatically at the opening of the cover.
Handling : Opening and handling of the cover without specific tools.

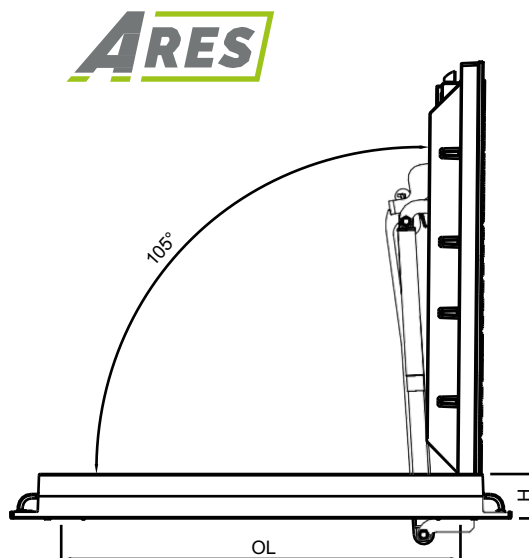
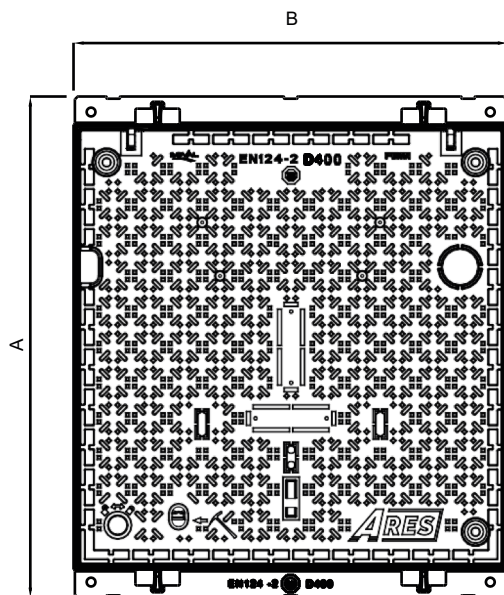

Ref.	Description	lay-out	Clear opening	A*	B*	H*	Total weight
				mm			Kg
38154	ARES		900 x 900	1130	980	102	224

*External frame measuress

All dimensions, weights and norms are given for information only. BERGTEC reserves the right to modify the specifications of products given in the present document.

2/2

MANHOLE COVER - LOCKED HINGED LIFT ASSISTED ARES CLASS D400



CABLE-PASS

2 dedicated **cable-pass** areas are pre-equipped on the ARES cover and can be quickly opened (**breakable plates in cast iron**).

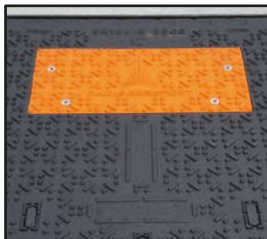

IDENTIFICATION FINITION & CUSTOMIZATION

On request :

- 1 badging area for customization of 450 x 250 mm by **casting on the cover** or with an insert plate made of powder-coated cast iron (color of your choice).
- 2 badging areas are available for customization of 180 x 40 mm with **stainless steel plates**.



SAFETY BLOCKING DEVICE



At the opening, **safety blocking device** (gravity pawl) automatically locks the cover and prevents the cover from being accidentally closed.

A locking pin in option adds an **extra level of safety**.



Easy closing & **effortless** by only rising the device.

Selflocking by means of ductile iron spring bar «Pushed - Slammed»

Associated products

