



HINGED HYDRAULIC ACCESS COVER
HYDR'O - CLASS C 250



PLACE OF INSTALLATION :

Group 2, Class C 250 : see EN 124-2

SPECIFICATIONS :

Norm : **EN 124-2 / NF 110**

Loading : **250 kN**

Quality Label : Afnor

MATERIAL & COATING :

Cover & Frame : Spheroidal Cast Iron
GS 500-7. Water Based Black Paint

REMARKS :

Hydraulic closing prevents odors rising
Hinged lid

OPTIONS :

Logo & Badging
1/4 turn lock

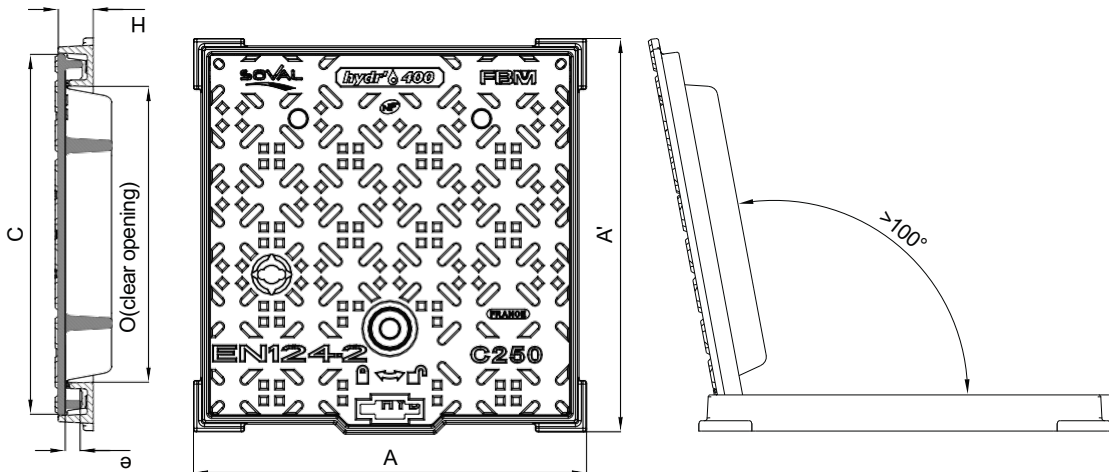

Description	Ref.		Dimension					Mass		
	Without lock	With lock	A x A'	C	Clear Opening	e	H	cover	total	surface
					mm			Kg		kg/m ²
Hydr'O 400	35524	35527	400 x 415	365	305 x 305	11	35	12,50	18,50	138,88
Hydr'O 500	35525	35528	500 x 515	465	400 x 400	11	35	17,50	25,50	109,50
Hydr'O 600	35526	35529	600 x 615	565	500 x 500	8	41	30,00	46,50	120,00