



**GRATING PASSEO
CLASS C250**



PLACE OF INSTALLATION :

Group 3, Class C 250 : see EN 124-2

SPECIFICATIONS :

Norm : **EN 124-2 / NF 110**

Loading : **250 kN**

Quality Label : Afnor

MATERIAL & COATING :

Cover & Frame : Spheroidal Cast Iron
GS 500-7. Water Based Black Paint

OPTIONS :

1/4 turn lock

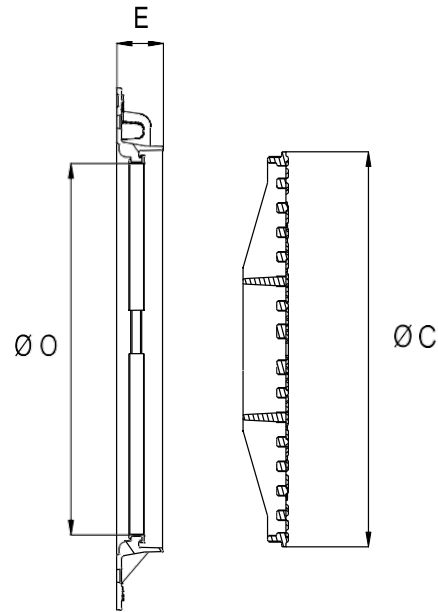
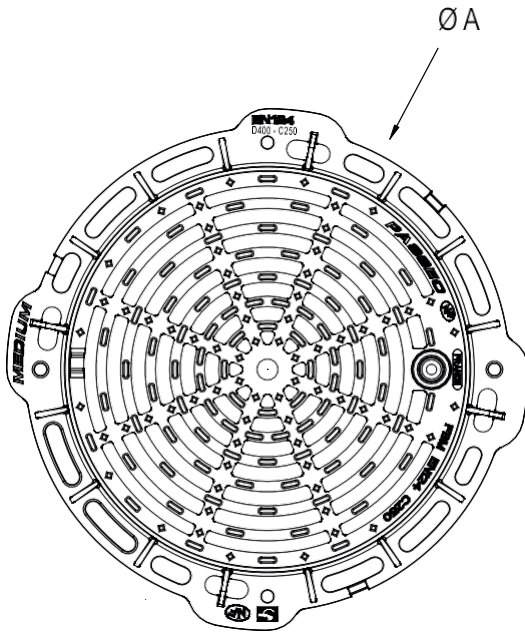

Ref.	Frame	Ø C	Ø O	Ø A	E	Absorption surface	Mass	
							grating	total
			mm			dm ²	Kg	
17916	Round	645	600	850	75	13,7	30	49

All dimensions, weights and norms are given for information only. BERGTEC reserves the right to modify the specifications of products given in the present document.