



GRATING FOR PIPE INSTALLATION N°160 TER PRM CLASS C250



PLACE OF INSTALLATION :

Group 3, Class C 250 : see EN 124-2
For PVC pipe 315 with EPDM gasket (ground)

SPECIFICATIONS :

Norm : EN 124-2 / NF 110

Loading : 250 kN

Quality Label : Afnor

MATERIAL & COATING :

Cover & Frame : Spheroidal Cast Iron
GS 500-7. Water Based Black Paint

Gasket : EPDM

REMARKS :

Hinged cover & anti-theft after sealing
PRM Friendly

OPTIONS :

SBR Gasket

Locking by Hexagon socket countersunk
head cap crew

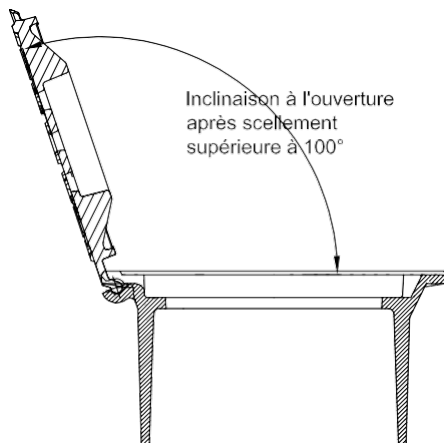

Inclinaison à l'ouverture
après scellement
supérieure à 100°

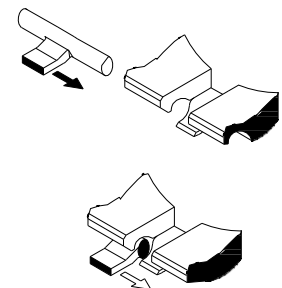
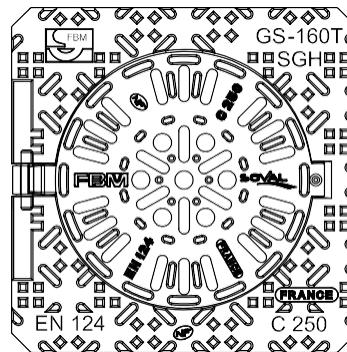

mise en place du tampon sur le
cadre par translation à 140°

| Ref. | N° | Clear opening | AxA | H | Absorption surface | Mass | |
|-------|---------|---------------|-----------|-----|--------------------|---------|-------|
| | | | | | | grating | total |
| | | | mm | | dm ² | Kg | |
| 28864 | 160 ter | Ø225 | 360 x 360 | 178 | 1,2 | 5 | 2,3 |